

4WRKE...type Electro-Hydraulic Proportional Directional Valve



4WRKE...3XJ type

Size 10, 16, 25, 32
Max. Working Pressure: 315 bar
Max. Flow: 1600 L/min

Contents

Function and configuration	02
Symbols	03
Ordering code	03
Technical data	04
Electrical connections	05
Characteristic curves	06-08
Unit dimensions	09-12

Features

- Pilot operated 2-stage proportional directional valve
- Valve for the control of the size and direction of a flow
- For subplate mounting, porting pattern to DIN 24 340 form A
- Spring centred main spool
- Integrated control electronics

Function and configuration

Proportional directional valve type 4WRKE...3XJ...

4WRKE type valve is a 2-stage proportional directional control valves. They control the size and direction of a flow. The main stage is closed loop position controlled so that the spool position is also independent of flow forces at larger flows.

The valve consists of the pilot control valve(1), housing (8), main spool (7), covers (5 and 6), centering spring (4), inductive position transducer (9) and the pressure reducing valve (3).

If no input signal is being applied then the main spool (7) is held in the center position by the centering spring (4). The two control chambers in the covers (5 and 6) are connected via the valve spool (2) to tank. The main spool (7) is connected to suitable control electronics via the inductive position transducer(9). The positional change of the main spool (7) as well as the alteration of the command value at the summation point of the amplifier produces a differential voltage.

With the command actual value comparison a possible control deviation is recognised via the electronics and an electrical current is applied to the proportional solenoid of the pilot valve (1).

The current induces, within the solenoid, a force which is passed on to the solenoid pin which in turn actuates the control spool. The flow which is provided via the control cross sections causes the main spool to move.

Pilot control valve type 4WRAP 6 W7...-3XJ/G24...

The pilot control valve is a direct operated proportional valve. The control edge geometrics were designed and optimised for the use as a pilot control valve for the proportional directional valves type 4WRKE.

The proportional solenoids are pressure tight, oil-immersed DC solenoids with removable coil. They convert an electrical current proportionally into a mechanical force. An increase in the current strength causes an appropriately higher solenoid force.

The valve consists of housing(1), proportional solenoids(2 and 3), spool(4) and springs(5 and 6).

In the de-energised condition both actuator ports are connected to tank. If one of the two solenoids (2 or 3) is energised, then the solenoid force moves the valve spool (4) against the spring (6 or 5).

Once the overlap area is overcome, the connection to tank of one of the two actuator ports is blocked and the connection to the pressure chamber is established. There is flow from P to the control chamber of the main stage.

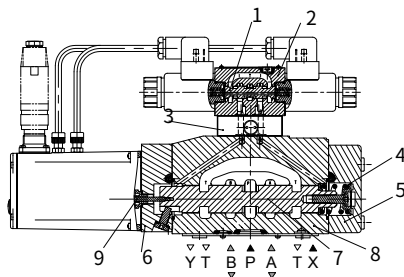

Type 4WRKE 16 ...-3XJ...

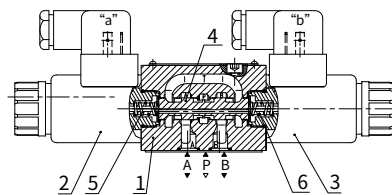

Type 4WRAP 6 W7...-3XJ/G24...

Technical data

General					
Nominal size		10	16	25	32
Installation and commissioning guidelines	Optional, preferably horizontal				
Storage temperature range	°C	- 20 to + 80			
Ambient temperature range	°C	- 20 to + 50			
Weight	kg	8.7	11.2	16.8	31.5

Hydraulic (measured at p=100bar, with HLP46 at $\vartheta_{oil} = 40^{\circ}\text{C} \pm 5^{\circ}\text{C}$)						
Operating pressure	-Pilot control valve	Pilot oil supply	bar	25 to 315		
	-Main valve	Ports P, A, B	bar	Up to 315	Up to 350	Up to 350
Return pressure	Port T (Pilot oil drain)	Internal	bar	Static < 10		
		External	bar	Up to 315	Up to 250	Up to 250
	Port Y		bar	Static < 10		
Nominal flow $q_{vnom} \pm 10\%$ at $\Delta p=10\text{bar}$ (Δp = valve pressure differential)	L/min	25	-	-	-	
		50	125	220	440	
Flow of main valve (max. permissible)	L/min	170	460	870	1600	
Pilot oil flow at port X or Y with a step form of input signal from 0 to 100 % (315 bar)	L/min	4.1	8.5	11.7	13	
Pressure fluid	Mineral oil(HL,HLP)to DIN 51 524 Phosphate ester (HFD-R)					
Pressure fluid temperature range	°C	10 to 80, preferably 40 to 50				
Viscosity range	mm ² /s	20 to 380, preferably 30 to 45				
Degree of contamination	Maximum permissible degree of contamination of the pressure fluid is to NAS 1638.			A filter with a minimum retention rate of $\beta_x = 75$ is recommended		
	Pilot control valve	Class 7		x = 5		
	Main valve	Class 9		x = 7		
Hysteresis	%	≤ 1				
Response sensitivity	%	≤ 0.5				

Electrical	
Voltage type	DC
Electrical connection	Plug-in connector to DIN EN175 201-804
Power, max.	W 72 (average = 24W)
Control electronics	Integrated into the valve

Electrical connections, plug-in connector

For pin allocation also see block circuit diagram.

Plug-in connector to DIN EN 175201-804

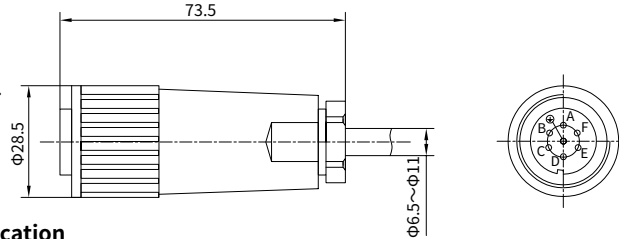

Component plug allocation

	Contact	Signal
Supply voltage	A	24 VDC (18 to 35 VDC); $I_{max} = 1, 5 \text{ A}$; impulse load $\leq 3 \text{ A}$
	B	0V
Ref. (actual value)	C	Ref. potential for actual value (contact F)
Differential amplifier input (command value)	D	$\pm 10\text{V}$ or 4 – 20mA
	E	0V ref. potential
Measurement output (act. value)	F	$\pm 10\text{V}$ or 4 – 20 mA
	PE	Connected with cooling body and valve housing

Command value:

Reference potential at E and a positive command value at D results in a flow from P to A and B to T.
Reference potential at E and a negative command value at D results in a flow from P to B and A to T.

Connection cable:

Recommendation: – Up to 25m cable length type LiYCY 7×0.75 mm²
– Up to 50m cable length type LiYCY 7×1.0 mm External diameter: – 6.5 to 11mm (plastic plug-in connection)
– 8 to 12mm (metal plug-in connector)
Connect screen to \perp only on supply side.

06

Block circuit diagram / connection allocation of the integrated control electronics for type 4WRKE

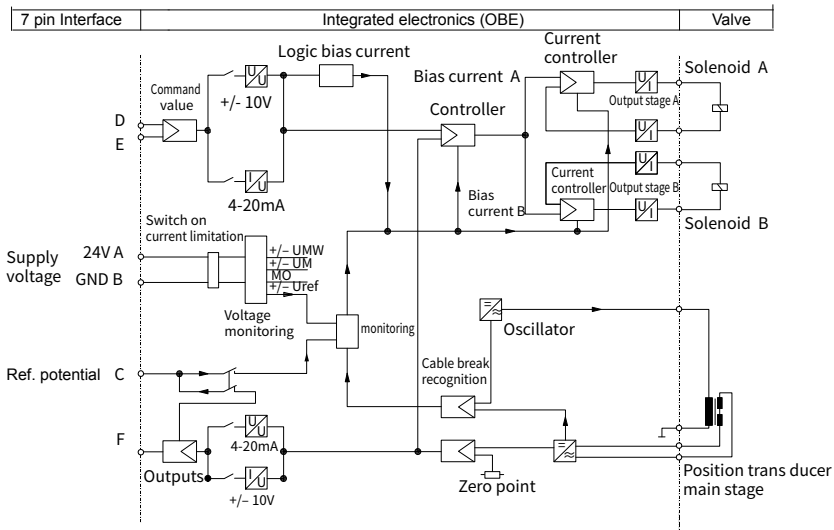

Characteristic curves (measured with HLP46, $\vartheta_{oil}=40^{\circ}\text{C} \pm 5^{\circ}\text{C}$)

Flow - command value curve

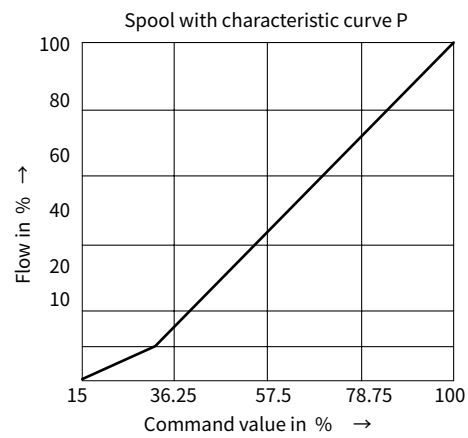
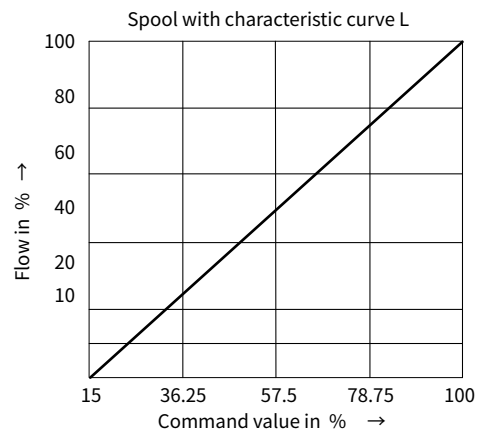

Characteristic curves (measured at $p=100\text{bar}$, with HLP46, $\vartheta_{\text{oil}}=40^\circ\text{C} \pm 5^\circ\text{C}$)

NG 10

Transient function with a step form of electrical input signal

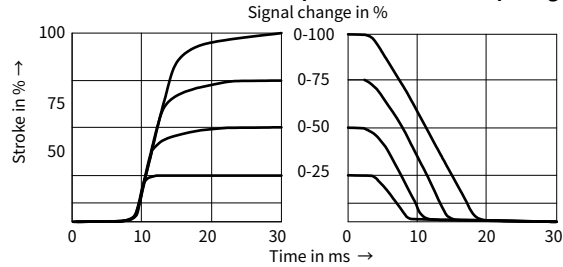

Flow-pressure differential curve

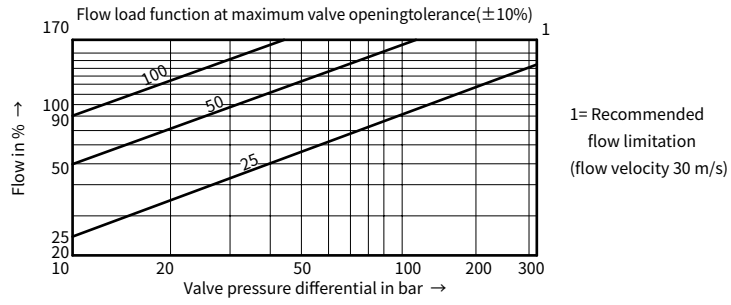

NG 16

Transient function with a step form of electrical input signal

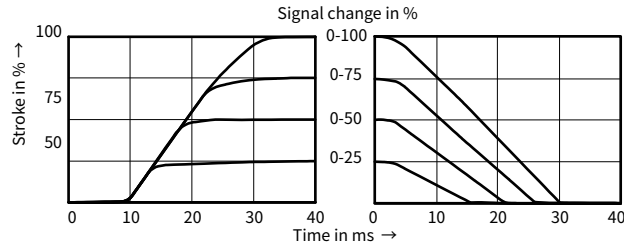

Flow-pressure differential curve

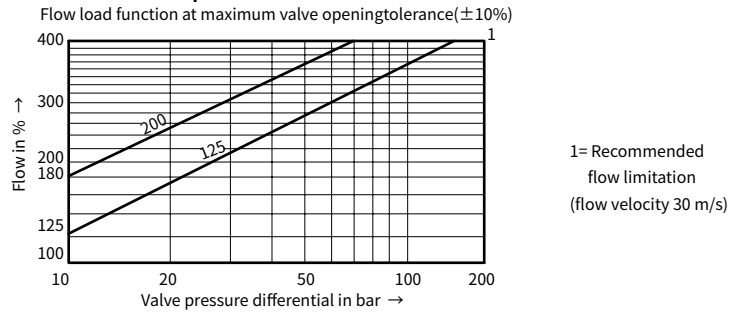

06

Characteristic curves (measured at p=100bar, with HLP46, $\vartheta_{oil}=40^{\circ}\text{C} \pm 5^{\circ}\text{C}$)

NG 25

Transient function with a step form of electrical input signal

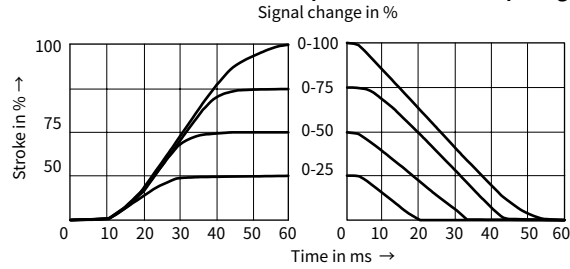

Flow-pressure differential curve

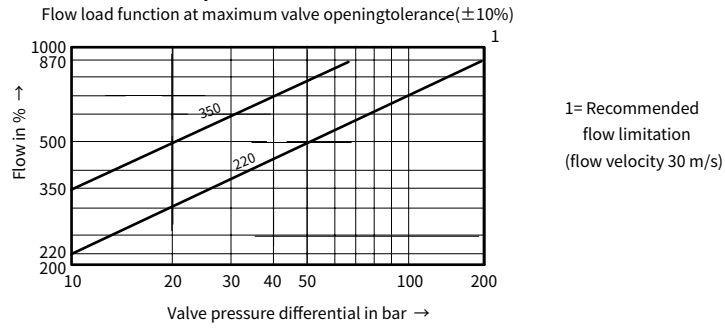

NG 32

Transient function with a step form of electrical input signal

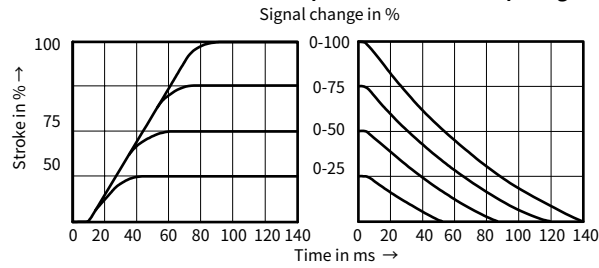

Flow-pressure differential curve

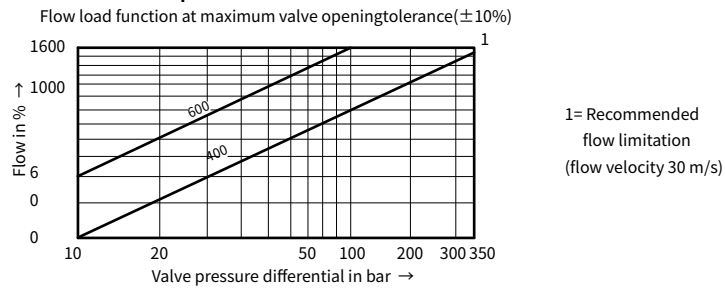

Unit dimensions

(Dimensions in mm)

NG 10

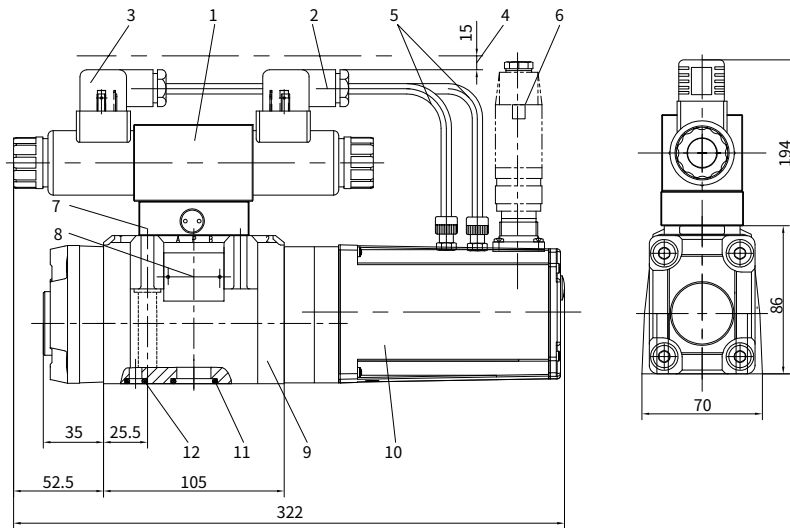

0.01/100mm

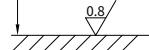

Required surface finish of mating piece

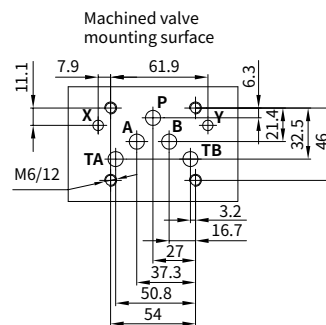

- 1 Pilot control valve
- 2 Plug-in connector "A"
- 3 Plug-in connector "B"
- 4 Space required to remove the plug-in connector
- 5 Cable
- 6 Plug-in connector
- 7 Pressure reducing valve
- 8 Name plate
- 9 Main valve
- 10 Integrated control electronics
- 11 R-ring $13 \times 1.6 \times 2$, ports A, B, P, T
- 12 R-ring $11.18 \times 1.6 \times 1.78$, ports X and Y

06

Unit dimensions

(Dimensions in mm)

NG 16

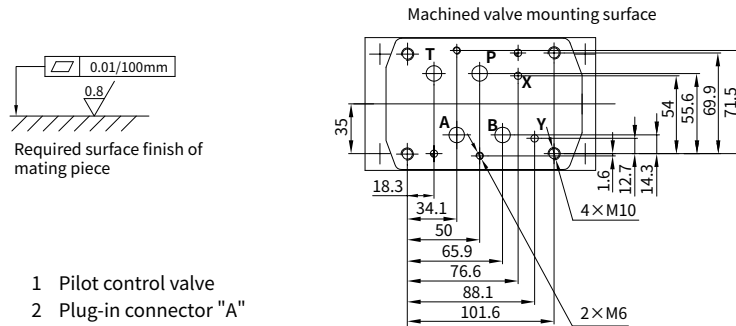
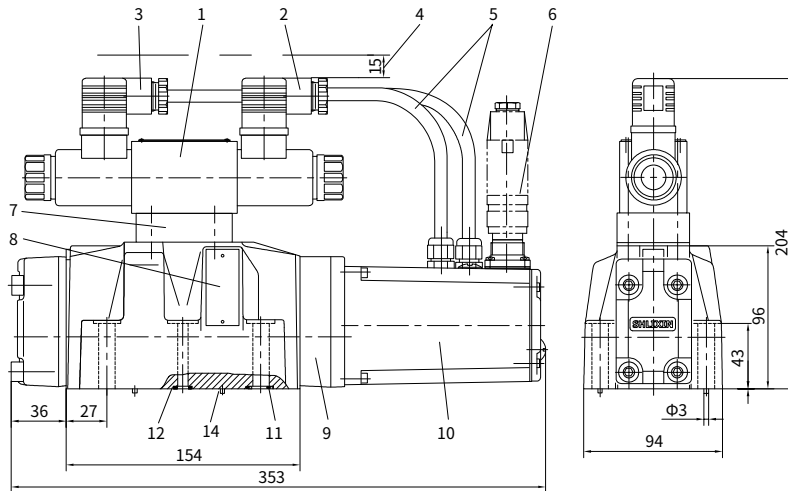

Required surface finish of mating piece

- 1 Pilot control valve
- 2 Plug-in connector "A"
- 3 Plug-in connector "B"
- 4 Space required to remove the plug-in connector
- 5 Cable
- 6 Plug-in connector
- 7 Pressure reducing valve
- 8 Name plate
- 9 Main valve
- 10 Integrated control electronics
- 11 R-ring 22.53×2.3×2.62, ports A, B, P, T
- 12 R-ring 10×2×2, ports X and Y
- 14 Locating pin

Unit dimensions

(Dimensions in mm)

NG 25

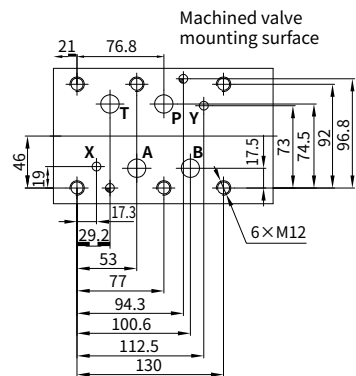
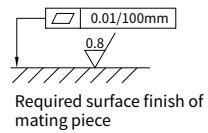
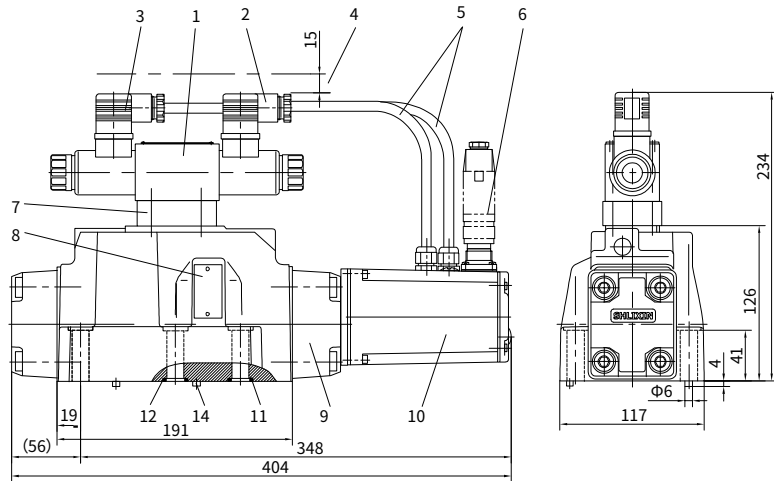

- 1 Pilot control valve
- 2 Plug-in connector "A"
- 3 Plug-in connector "B"
- 4 Space required to remove the plug-in connector
- 5 Cable
- 6 Plug-in connector
- 7 Pressure reducing valve
- 8 Name plate
- 9 Main valve
- 10 Integrated control electronics
- 11 R-ring 27.8×2.6×3, ports A, B, P, T
- 12 R-ring 19×3×3, ports X and Y
- 13 Locating pin

06

Unit dimensions

(Dimensions in mm)

NG 32

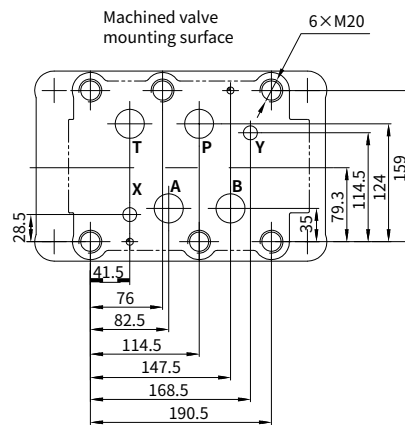
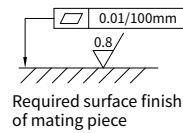
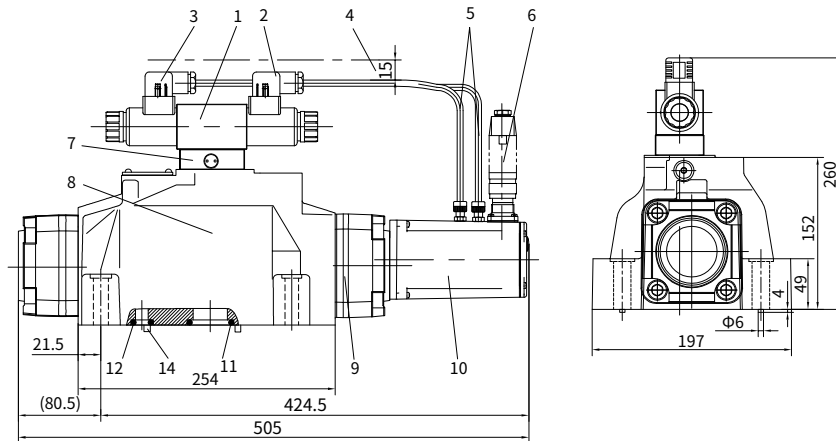

- 1 Pilot control valve
- 2 Plug-in connector "A"
- 3 Plug-in connector "B"
- 4 Space required to remove the plug-in connector
- 5 Cable
- 6 Plug-in connector
- 7 Pressure reducing valve
- 8 Name plate
- 9 Main valve
- 10 Integrated control electronics
- 11 R-ring 42.5×3×3, ports A, B, P, T
- 12 R-ring 19×3×3, ports X and Y
- 13 Locating pin

