

HED4...type Pressure Relay

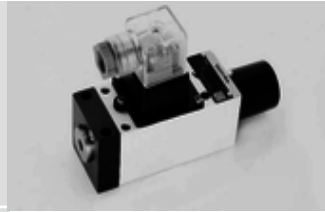

HED4... 1XJ...type

Max. Working Pressure: 350bar

Contents

Function and configuration	02
Terminal allocation	02
Circuit example	02
Specifications	03
Technical data	03
Characteristic curves	04
Unit dimensions	05-07
Installation guidelines	08

Features

- For sub-plate mounting
- For pipe installation
- Vertical stacking piece in the horizontal assembled valves

Function and configuration

HED4 type relay is a piston pressure relay . It consists of the housing(1), cartridge with spool (2),compression spring (3), adjustment element (4) and switch(5).

The pressure fluid is applied to the piston (2) , then the piston (2) supports itself on the spring seat (6) and acts against the infinitely adjustable force of the compression spring (3).

The spring seat (6) transfers the movement of the piston (2) to the switch (5). The switch (5) acts on-off as the designing requirement.

Type HED 4 OA 1XJ/...

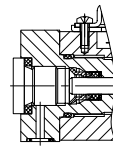
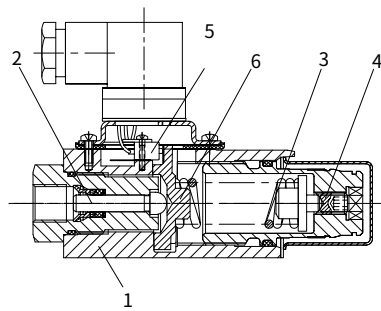

Type HED 4 OP 1XJ/...

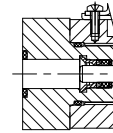

Type HED 4 OH 1XJ/...

Terminal allocation

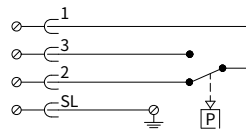
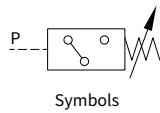

Terminal connection-Z14 small-scale plug

Specification

	HED4	-1XJ/	Z14/		*	
Pressure relay						Further details in clear text
Sub-plate mounting	=OP					No code = NBR seals
Pipe installation	=OA					V = FKM seals
Vertical stacking systems	=OH					Connection thread: Inch threaded (G1/4)
Series 10J to 19J	=1XJ					2 = Metric threaded (M14×1.5)
max. adjustable pressure	50bar = 5					Z14 = small-scale plug-in
max. adjustable pressure	100bar = 10					
max. adjustable pressure	350bar = 35					

Technical data

Fluid	Mineral oil suitable for NBR and FKM seal Phosphate suitable for FKM seal				
Fluid temperature	°C	- 20 ~ + 80 (for FKM seal)			
	°C	- 30 ~ + 80 (for NBR seal)			
Viscosity range	mm ² /s	2.8~500			
Degree of contamination:	Maximum permissible degree of fluid contamination: NAS 1638 class 9. and ISO4406 20/18/15				
Switching accuracy (repeatability)	%	<±1% of setting range			
Permissible switching frequency	times/min	120			
Electrical connection	Plug-in connector to DIN 43 650 form A, 3...pin +PE				
Rated pressure(bar)	Max. setting pressure (bar)	Offset pressure (bar)		Act pressure (bar)	
		min	max	min	max
50	50	2	46	4	50
100	100	3	89	8	100
350	350		322	20	350
Max. connection cross sectional area	mm ²	1.5			
Protection degree to DIN 43650	IP 65				
(With DC inductive loading, a spark suppresser must be provided in order to increase the service life .)					
Contact load:	AC	250V/5A;			
	DC	50V/1A, 250V/0.2A			
Weight	pressure switch	0.6			
	stacking plate	0.8 (size 6) 1.9 (size 10)			

Characteristic curves

(Measured at $t=40^{\circ}\text{C} \pm 5^{\circ}\text{C}$, using HLP46)

Rated pressure 50bar

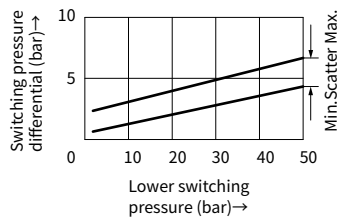

Rated pressure 100bar

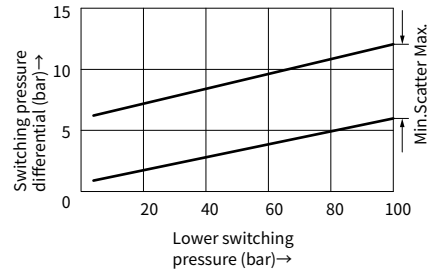

Rated pressure 350bar

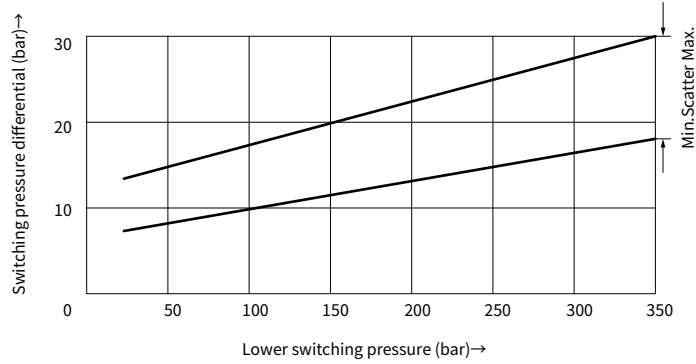

Unit dimensions

(Dimensions in mm)

- Stacking plate size 6 (for HED4 OH...vertical stacking)

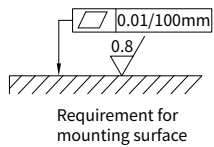
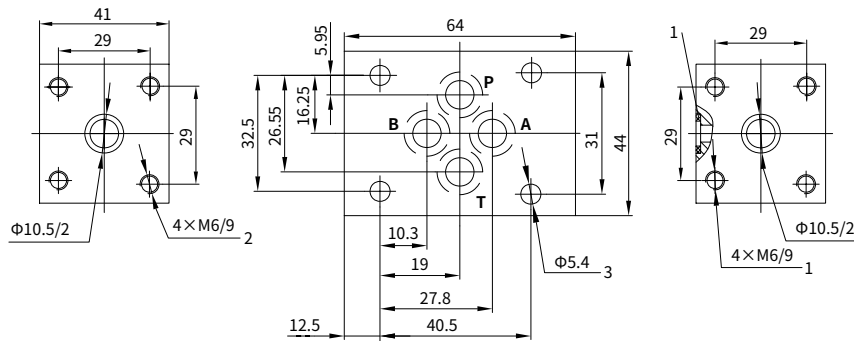

- 1 O-ring 9.25×1.78
- 2 Fixing screw holes of pressure switch
- 3 Fixing screw holes of stacking plate size 6

Pipeline for pressure switch						
Type	NBR	308400	308401	308402	308403	308404
	FKM	308436	308437	308438	308439	308440
Pipeline for pressure switch						
Type	NBR	308405	308406	308407	308408	317606
	FKM	308441	308442	308443	308444	317607

08

Unit dimensions

(Dimensions in mm)

- Stacking plate size 10 (for HED4 OH...vertical stacking)

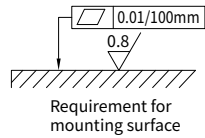
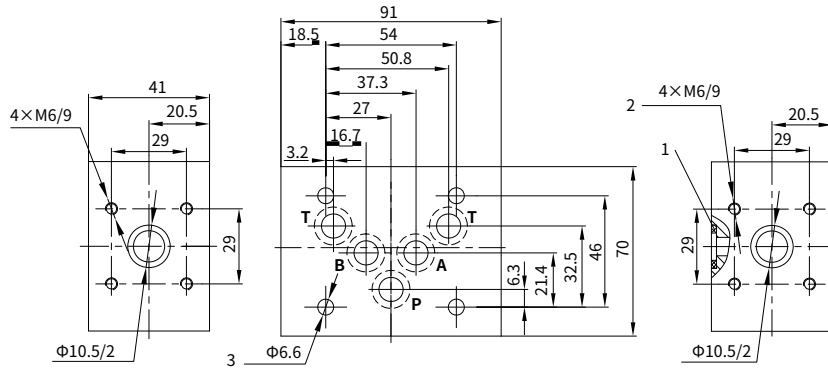

- 1 O-ring 12×2
- 2 Fixing screw holes of pressure switch
- 3 Fixing screw holes of stacking plate size 10

Pipeline for pressure switch						
Type	NBR	308409	308410	308411	308412	308413
	FKM	308445	308446	308447	308448	308449
Pipeline for pressure switch						
Type	NBR	308414	308415	308416	308417	317608
	FKM	308450	308451	308452	308453	317609

Installation guideline

(Dimensions in mm)

• For applying the pressure relay HED4 OH...in stacking assemblies size 6

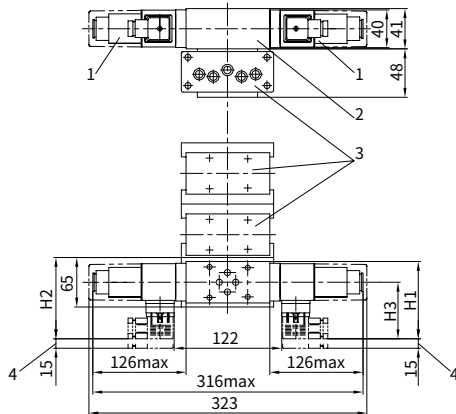

- 1 Pressure switch HED4OH...for use in stacking assemblies(can be rotated $4 \times 90^\circ$ for mounting).
The mounting possibilities of the pressure switch depends on the design of the adjacent stacking plates.
- 2 Stacking plate size 6 used.
for mounting stacking pressure switch.
- 3 Horizontal assembling module.
- 4 Space required to remove the plug-in connector.

• For applying the pressure relay HED4 OH...in stacking assemblies size 10

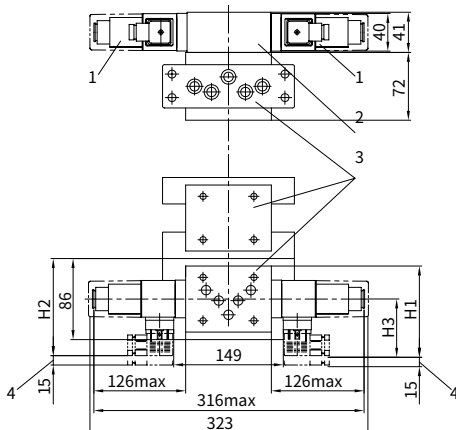

- 1 Pressure switch HED4OH...for use in stacking assemblies(can be rotated $4 \times 90^\circ$ for mounting).
The mounting possibilities of the pressure switch depends on the design of the adjacent stacking plates.
- 2 Stacking plate size 10 used.
for mounting stacking pressure switch.
- 3 Horizontal assembling module.
- 4 Space required to remove the plug-in connector.

Size	H1	H2	H3
6	95	98	74
10	108	116	74

